

Series	FD45,B	Max. Pressure	4000 psi
Shut Off	Double	Sleeve Material	Steel
Standards	ISO-7241-1 Series B	Connection Type	FNPT
Seal Type	Captive Valve	Coupler Flow Rate	12.0 gpm
Seal Material	Buna	Locking Mechanism	Ball
Valve Design	Poppet	Coupler Thread Size	1/2"-14

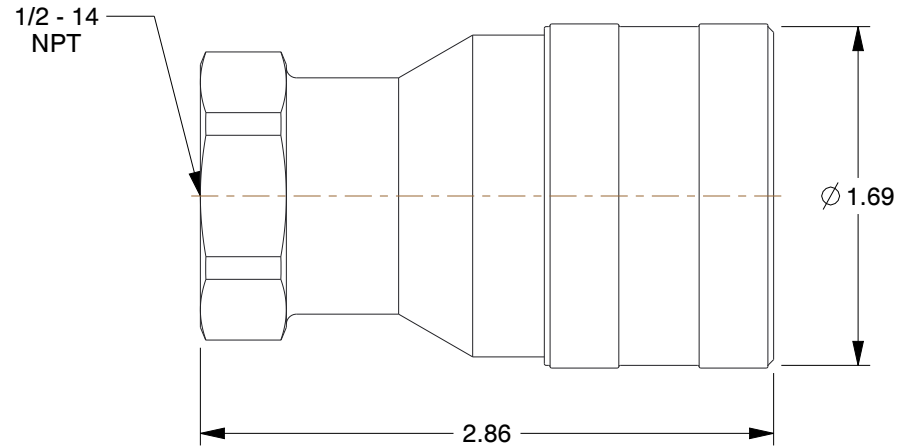
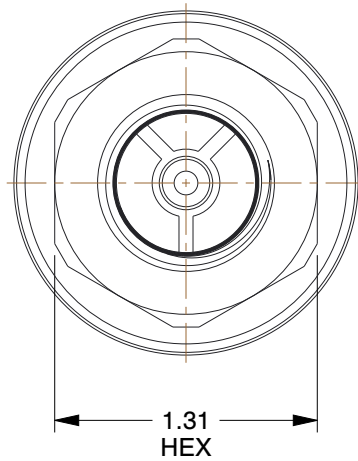

**NOTES:**

1. COUPLER BODY SIZE: 5/8"
2. ITEM: Hydraulic Coupler Body
3. PARKER INTERCHANGE: H4-62
4. HANSEN INTERCHANGE: 4-H26
5. COUPLER BODY MATERIAL: Steel
6. FOR USE WITH: All Hydraulic Applications
7. OPERATING TEMP. RANGE: -40° to 250°F
8. COUPLER FINISH: Trivalent Chromium Zinc
9. COUPLER INTERCHANGE TYPE: ISO Series B
10. QUICK COUPLER TYPE: Hydraulic Coupler Body

<b>COMPONENT</b>	Hydraulic Quick Couplers
------------------	--------------------------



100 Grainger Parkway, Lake Forest, Illinois 60045-5201  
 1-(800) GRAINGER, 1-(800) 472-4643, (847) 535-1000  
 www.grainger.com

This file and any associated information and specifications are provided for reference and evaluation purposes only, and is subject to change without notice. Grainger makes no representations, warranties or guarantees as to the appropriateness, accuracy, completeness, or suitability for any purpose, of the file, information or specifications. You are solely responsible for the use of the file, information or specifications.

This drawing is the property of GRAINGER. It contains confidential, proprietary information that is GRAINGER property. Do not disclose to or duplicate for others except as authorized by GRAINGER.

**SCALE** 1.04

<p><b>2F629</b></p> <p>Coupler Body, 1/2-14, 5/8 In. Body, Steel</p>	<b>UNIT</b>
	INCH
	<b>SHEET</b>
	1 of 1