

Product information presented here reflects conditions at time of publication. Consult factory regarding discrepancies or inconsistencies.



**PUMP COMPANY**

Zoeller Family of Water Solutions™

MAIL TO: P.O. BOX 16347 • Louisville, KY 40256-0347  
SHIP TO: 3649 Cane Run Road • Louisville, KY 40211-1961  
(502) 778-2731 • 1 (800) 928-PUMP • FAX (502) 774-3624

visit our web site:  
[www.zoeller.com](http://www.zoeller.com)

**COMPARE THESE FEATURES**

- Non-clogging vortex impeller design
- Float operated, 2-pole switch
- Durable cast iron construction. Cast iron switch cap, motor, and pump housing.
- Engineered plastic base
- Stainless steel screws, bolts, handle, guard, arm and seal assembly
- Engineered, glass-filled, plastic impeller with metal insert
- UL listed 3-wire cord and plug. 15 ft. cord standard for automatic & nonautomatic
- Corrosion-resistant powder coated epoxy finish
- Motor - .4 HP 115V & 230V, 1Ph, 60 Hz, 1725 RPM, oil filled PSC motor, hermetically sealed, automatic reset thermal overload protection
- Upper and lower sleeve bearings running in bath of oil
- Carbon and ceramic shaft seal
- Passes 2" spherical solids
- 2" NPT Discharge
- On point - 12-1/2" • Off point - 4-1/2"

**Note:** The sizing of effluent systems normally requires variable level float(s) controls and properly sized basins to achieve required pumping cycles or dosing timers with nonautomatic pumps.

**SIMPLEX AND DUPLEX SYSTEMS AVAILABLE**

**264 SERIES**

**“WASTE-MATE”**

(For Pump Prefix Identification see News & Views 0052)

**SUBMERSIBLE  
SEWAGE/EFFLUENT\*  
OR DEWATERING PUMP**

**2" NPT DISCHARGE**



Tested to UL Standard UL778  
& Certified to CSA  
Standard C22.2 No. 108



DESIGNED • MACHINED • ASSEMBLED  
IN THE USA



C SA US



**POWDER  
COATED  
TOUGH™**



SSMA  
Certified  
50  
YEARS



**MODELS AVAILABLE**

- Automatic
- Nonautomatic (for variable level systems)
- BE & BN264 available packaged with Piggyback variable level float switch.

\* May be used in those states where codes do not restrict solids size in effluent systems.

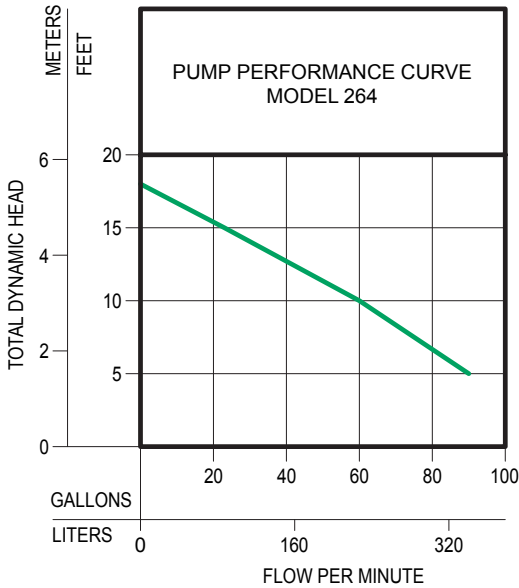

TOTAL DYNAMIC HEAD/FLOW  
SEWAGE AND DEWATERING

MODEL		264	
Feet	Meters	Gallons	Liters
5	1.5	90	341
10	3.0	60	227
15	4.6	23	87
009931 Shut-off Head:		18 ft (5.5 m)	

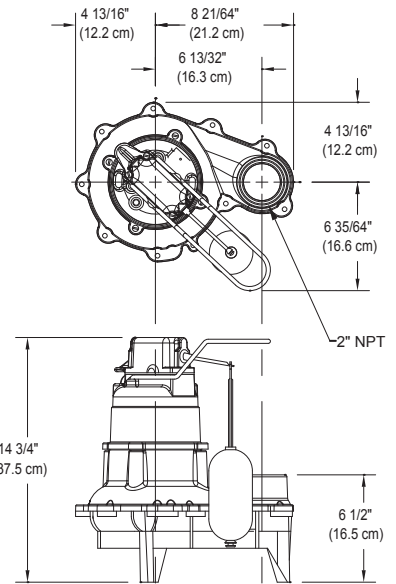

SK1643

## CONSULT FACTORY FOR SPECIAL APPLICATIONS

- Electrical alternators for duplex systems available with variable level float switches
  - Minimum recommended basin size  
Simplex - 18"x30"  
Duplex - 30"x36"
  - Standard Automatic - Weight 35.5 lbs. .4 HP
  - High water alarms available
  - Mechanical alternators available for duplex systems
- ▲ CAUTION** Maximum temperature of sewage or dewatering must be limited to 130°F (54°C). For over 130°F (54°C) special quotation required.
- | <ul style="list-style-type: none"> <li>• For "M" and "D" models, the approximate gallons pumped out per cycle are:</li> </ul> | <table border="1" style="width: 100%; border-collapse: collapse;"> <thead> <tr> <th style="text-align: left;">Tank Diameter</th> <th style="text-align: left;">Gallons Pumped</th> </tr> </thead> <tbody> <tr> <td>18" Simplex</td> <td>8 Gallons</td> </tr> <tr> <td>24" Simplex</td> <td>15 Gallons</td> </tr> <tr> <td>30" Duplex</td> <td>22 Gallons</td> </tr> <tr> <td>36" Duplex</td> <td>33 Gallons</td> </tr> <tr> <td>48" Duplex</td> <td>60 Gallons</td> </tr> </tbody> </table> | Tank Diameter | Gallons Pumped | 18" Simplex | 8 Gallons | 24" Simplex | 15 Gallons | 30" Duplex | 22 Gallons | 36" Duplex | 33 Gallons | 48" Duplex | 60 Gallons |
|---|---|---------------|----------------|-------------|-----------|-------------|------------|------------|------------|------------|------------|------------|------------|
| Tank Diameter   | Gallons Pumped  |               |                |             |           |             |            |            |            |            |            |            |            |
| 18" Simplex   | 8 Gallons   |               |                |             |           |             |            |            |            |            |            |            |            |
| 24" Simplex   | 15 Gallons  |               |                |             |           |             |            |            |            |            |            |            |            |
| 30" Duplex  | 22 Gallons  |               |                |             |           |             |            |            |            |            |            |            |            |
| 36" Duplex  | 33 Gallons  |               |                |             |           |             |            |            |            |            |            |            |            |
| 48" Duplex  | 60 Gallons  |               |                |             |           |             |            |            |            |            |            |            |            |

264 MODELS				CONTROL SELECTION		
Model	Volts	Ph	Mode	Amps	Simplex	Duplex
M264	115	1	Auto	9.4	1	4
N264	115	1	Non	9.4	2 or 3	4
D264	230	1	Auto	4.7	1	4
E264	230	1	Non	4.7	2 or 3	4

### SELECTION GUIDE

1. Integral float operated mechanical switch, no external control required.
2. For automatic use single piggyback variable level float switch or double piggyback variable level float switch. Refer to FM0477.
3. See FM1228 for correct model of simplex control panel.
4. See FM0712 for correct model of duplex control panel or FM1663 for a residential alternator system.

**▲ CAUTION**

For information on additional Zoeller products refer to catalog on Piggyback Variable Level Float Switches, FM0477; Electrical Alternator, FM0486; Mechanical Alternator, FM0495; Sump/Sewage Basins, FM0487, and Single Phase Simplex Pump Control, FM1596; Alarm System, FM0732.

All installation of controls, protection devices and wiring should be done by a qualified licensed electrician. All electrical and safety codes should be followed including the most recent National Electric Code (NEC) and the Occupational Safety and Health Act (OSHA).

## RESERVE POWERED DESIGN

For unusual conditions a reserve safety factor is engineered into the design of every Zoeller pump.



**PUMP COMPANY**

MAIL TO: P.O. BOX 16347 • Louisville, KY 40256-0347  
SHIP TO: 3649 Cane Run Road • Louisville, KY 40211-1961  
(502) 778-2731 • 1 (800) 928-PUMP • FAX (502) 774-3624

**Your Peace of Mind is Our Top Priority®**

**visit our web site:  
[www.zoeller.com](http://www.zoeller.com)**