

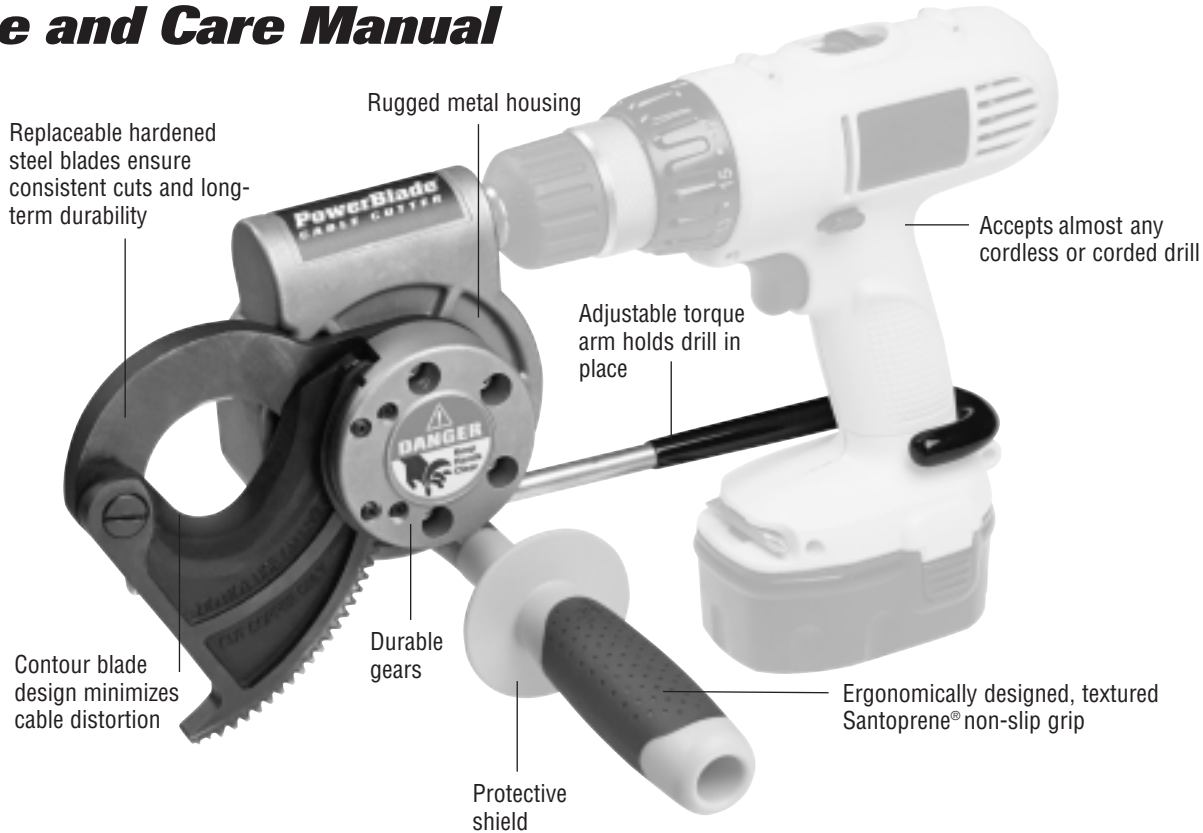

PowerBlade™ Cable Cutter

#35-078

Use and Care Manual



Specifications	
Cable Cutter Assembly:	35-078
Drill Specifications:	Any drill 12V or larger that accepts 3/8" drive shaft
Cutting Capacity:	750 MCM Hard Drawn Copper and up to 2" O.D. Aluminum
RPM Specifications:	Maximum of 2000 RPM Optimal RPM: 1500

Operating Precautions

1. Do not drop or abuse the unit.
2. Do not disassemble, repair or modify the assembly, except to replace parts as shown on page 3.
3. Do not expose the unit to water or solvents.
4. Do not cut cables larger than those listed in the specifications.
5. Set drill to 1500 RPM for best performance. **Cutting large cable at high RPM will damage gears!**
6. Do not use tool in the rain to prevent blade wear and malfunction.
7. Store cutter in case provided, in a dry, secure area.
8. We strongly recommend using a reversible drill to enable backing out of a cut when necessary.

WARNINGS

1. Do not overreach. Keep proper footing and balance at all times.
2. Keep out of reach of children.
3. Always wear safety glasses when using this tool.
4. Do not use on live circuits. Always disconnect power before using this tool.
5. Keep hands away from blades while operating unit.
6. Never operate tool without torque arm installed.
7. Blade is sharp; contact with blade can result in serious personal injury.
8. Disconnect drill from power source before servicing. Always remove drill from unit before attempting to change blades.

Do not cut steel, ACSR or any other materials containing steel or damage to blades will result.



Each unit is tested before shipment. Copper residue on blades may remain from the initial quality inspection test cut.

Global Patents Pending

Failure to heed all warnings and precautions outlined in this manual may lead to serious personal injury.



Operating Instructions

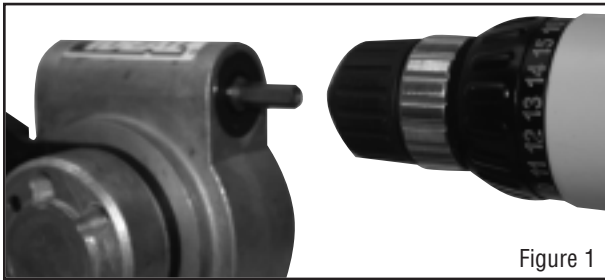

Figure 1

STEP 1: Attach cable cutter drive shaft to drill as shown (Figure 1). Tighten drill chuck securely.

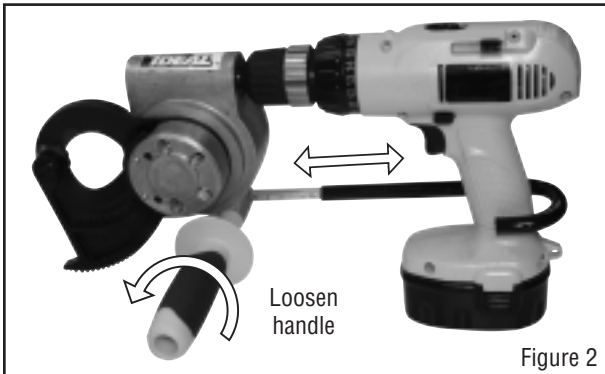

Figure 2

STEP 2: Loosen handle so torque arm extends freely (Figure 2).

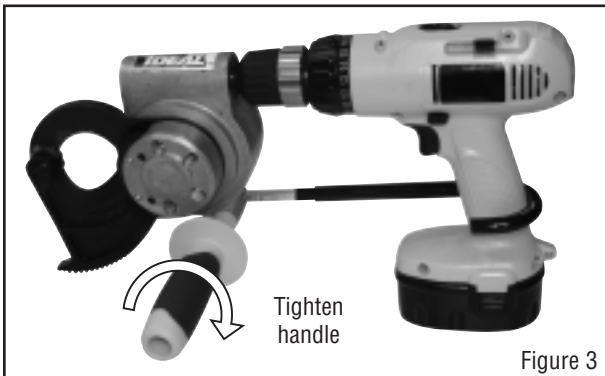

Figure 3

STEP 3: Loop torque arm around drill handle and tighten handle into locking collar to lock torque arm in place (Figure 3). Do not operate tool without torque arm in place.

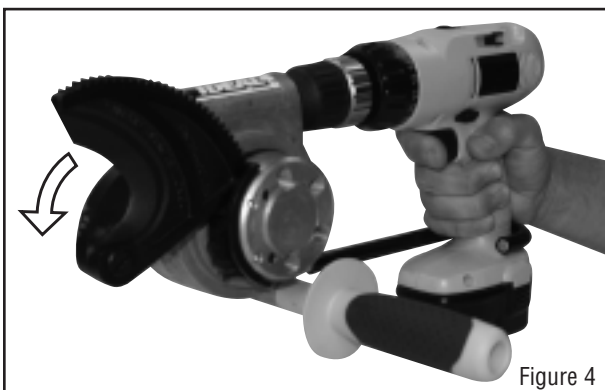

Figure 4

STEP 4: Activate the drill trigger switch to open the moving blade (Figure 4).

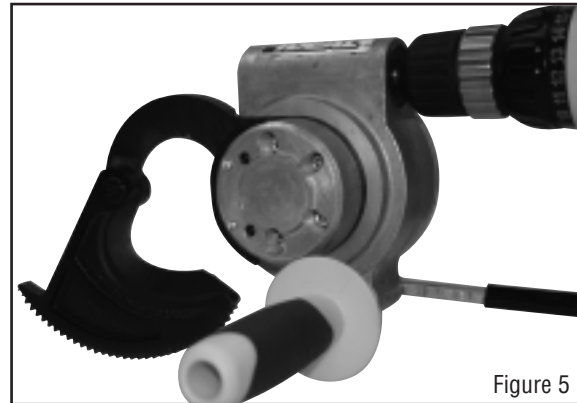

Figure 5

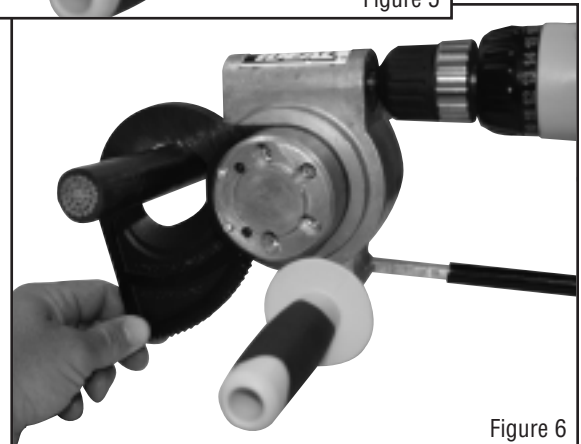

Figure 6

STEP 5: Place the cable to be cut onto the stationary blade and close the moving blade around the cable. Feed the moving blade by hand until the first gear teeth are engaged (Figure 5 and 6).

STEP 6: Press the drill trigger switch until cable is completely cut. Reverse mode on drill can be used to back off blade if necessary.

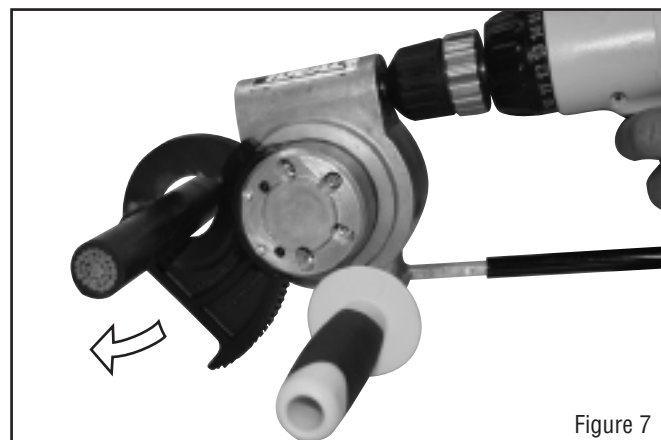
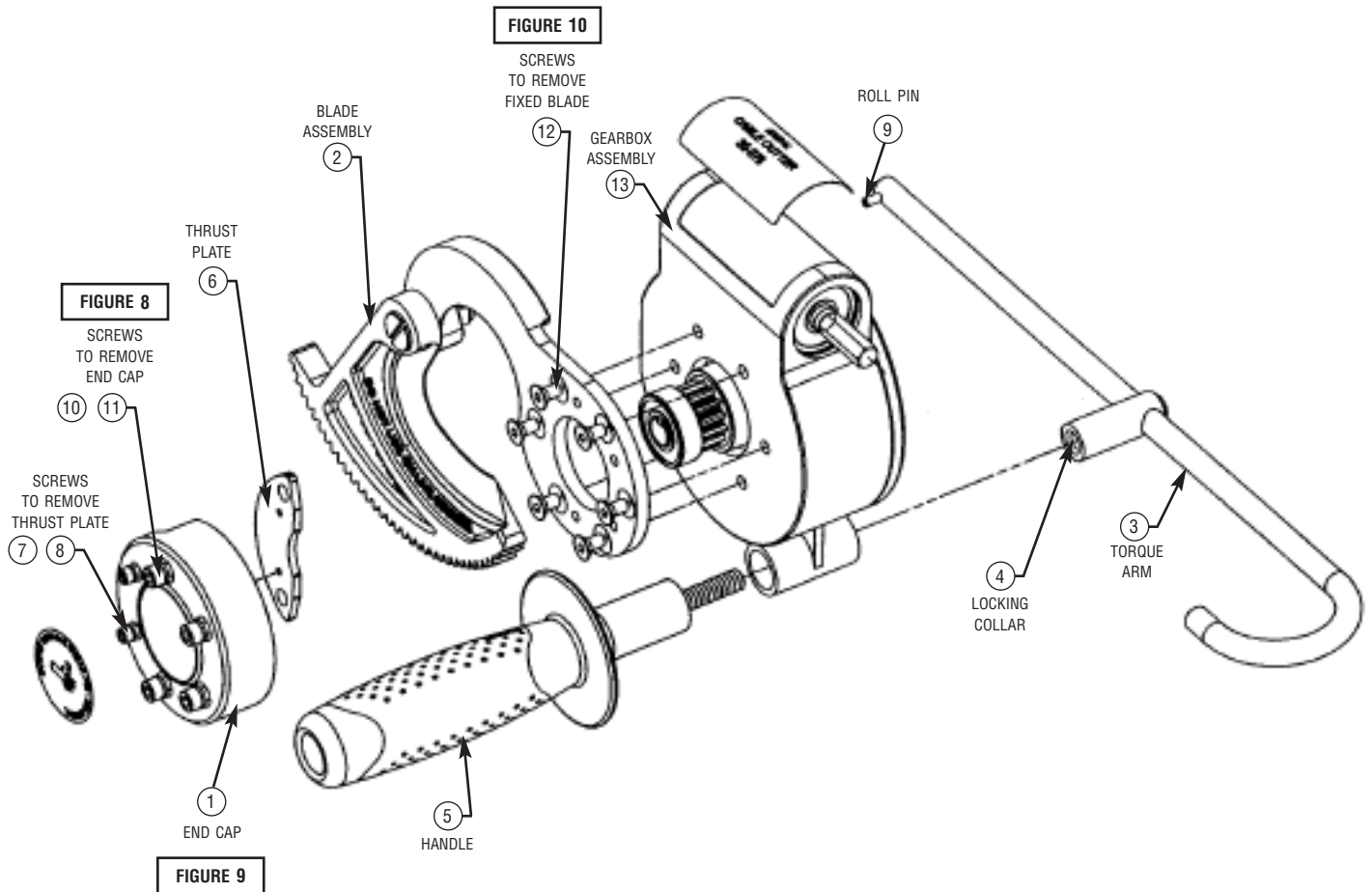

Figure 7

STEP 7: To cut several small cables continuously, cut first cable as described above, then reverse blade until opening is sufficient to feed the next cable through. Continue to alternate between forward and reverse modes until all cables are cut (Figure 7).

STEP 8: When finished, remove any dust or particles that may have become attached to the blade.

Blade Replacement, Parts and Accessories



Blade Replacement (See exploded view above)

Your Drill-Powered Cable Cutter unit is designed for easy blade replacement. If blade damage occurs that cannot be filed away, or if blades are accidentally used on steel or ACSR, replace **both** blades as described below:

1. Disconnect drill from power source or battery, then detach unit from drill. Do not attempt blade replacement with drill attached.
2. Remove four hex screws from end cap that sits on top of the fixed blade using a 5/32" hex wrench (Figure 8).
3. Remove end cap from unit (Figure 9).
4. Remove 6 hex screws attaching blade to body, using a 1/8" hex wrench (Figure 10).
5. Remove blade assembly.
6. Replace with a new blade set, IDEAL part #K-8906R.
7. Reinstall using screws removed earlier.

Always replace blades in sets for optimal performance. Replacing only one side will increase wear and shorten overall blade life.

Handle Replacement

The comfort handle can be unscrewed and replaced if necessary. Order IDEAL replacement handle part #K-8947R. Replacement torque arm assemblies can also be ordered. IDEAL part #K-8909 includes torque arm, locking collar and roll pin.

ITEM NO.	PART NO.	DESCRIPTION	H-3413-User Guide/QTY.
1		END CAP	1
2	K-8906R	BLADE PAIR ASSEMBLY	1
3	K-8909	TORQUE ARM	1
4	LA-4192	LOCKING COLLAR	1
5	K-8947R	HANDLE	1
6	K-9076	THRUST PLATE	1
7	113.161	6-32 HSCS X .375 LG. HEX SCREW	2
8	633.041	#6 LOCK WASHER	2
9	281.106	.125 DIA X .625 ROLL PIN	1
10	113.191	10-32X.500 SHCS HEX SCREW	4
11	633.059	#10 SPLIT LOCK WASHER	4
12	113.190	10-32X.375 FHMS HEX SCREW	6
13		GEARBOX ASSEMBLY	1
14	K-8926	CARRYING CASE	

Warranty

One year limited warranty. Warranty limited solely to repair or replacement; no warranty of merchantability, fitness for a particular purpose or consequential damages. 90 day warranty on blades.



Maintenance and Inspection

1. Frequent maintenance is important to keep the tool in good working condition.
2. To ensure smooth operation and prevent rust, store the tool in a cool, dry area.
3. Ensure that blades are clean and sharp for optimal performance.
4. Inspect blades for damage or burrs. If burrs exist, they can be removed with a flat grinding stone or file on the back sides of the blades.
5. Keep handle and torque arm dry, clean and free from oil or grease. These can be cleaned with a soft cloth using mild soap and water. Do not submerge gear box in water. Wipe unit completely dry after cleaning.
6. Occasionally oil blades with a light cutting oil.
7. If the tool is maintained regularly, it should provide you with trouble-free service.
8. The large shoulder screw used to attach the blades together may loosen during use, especially when making many cuts on larger cable sizes (750 MCM), or when blades become dull. Tighten shoulder screw, then loosen 1/4 turn to adjust. If this screw loosens too frequently, or if blades smash cable instead of cutting, replace blade assembly as shown on page 3.
9. For best cutting results, we recommend replacing blades after 400-600 cuts on 750 MCM cable.
10. A generic shear pin locks the output gear to the output shaft. If too much torque is placed on the pin and it is damaged, it can be replaced with a standard 1/8 square key, available at your local hardware store.

Gearbox is lubricated and sealed for the life of the tool. Do not open the gearbox for any reason; opening will void all warranties.



IDEAL INDUSTRIES, INC.

Becker Place, Sycamore, IL 60178, USA / 815-895-5181 • 800-435-0705 in USA
33 Fuller Road, Ajax, Ontario, L1S 2E1, Canada / 905-683-3400 • 800-527-9105 in Canada
225 Europa Boulevard, Gemini Business Park, Warrington, Cheshire WA5 7TN, UK / +44-(0) 1925 444446
Gutenbergstrasse 10, 85737 Ismaning, Germany / +49-(0) 89 996860
Level 6, 75-85 Elizabeth Street, Sydney NSW 2000 Australia / 61300 765 800
Unit 505, Tower W1, The Towers, Oriental Plaza, No. 1 East Chang An Avenue,
Dong Cheng District, Beijing, 100738, China / 86-10-8518-3141
Condomínio América Business Park, Cj 201 Edifício Quebec,
Av. Marginal do Rio Pinheiros No. 5200,
CEP 05693-000 São Paulo - Brasil / 55-11-3759-8777
Prol. Americas 1600 4to. Piso, Col. Country Club / Guadalajara, Jal. 44610, Mexico
ph: 52-33-36789176 • 52-33-10688902 (mobile) • fax: 52-33-36789290
www.idealindustries.com

**Innovation by IDEAL,
the Brand Electricians Trust**