

## A19ANC, A19ANF, A19APC NEMA Type 3R Thermostats

### Application

The A19ANC, A19ANF and A19APC thermostats are designed for a variety of applications where rainproof enclosures are necessary or desirable.

**IMPORTANT:** The A19 Series thermostats are intended to control equipment under normal operating conditions. Where failure or malfunction of an A19 thermostat could lead to an abnormal operating condition that could cause personal injury or damage to the equipment or other property, other devices (limit or safety controls) or systems (alarm or supervisory) intended to warn of or protect against failure or malfunction of the A19 thermostat must be incorporated into and maintained as part of the control system.

### Features

- Rainproof gasketed enclosure is U.L. Listed for outdoor use.
- Liquid-filled element is unaffected by barometric pressure and cross-ambient temperatures.
- Dependable field proven, snap-acting switch is rated for inductive or resistance loads (See Electrical Ratings table).
- Wide choice of range options.
- Simple strain-free mounting on three rubber cushioned mounting feet.
- High temperature dial stop.
- Copper bulb well available.

### General Description

The thermostats have an enclosed SPDT switch. The red terminal is common.

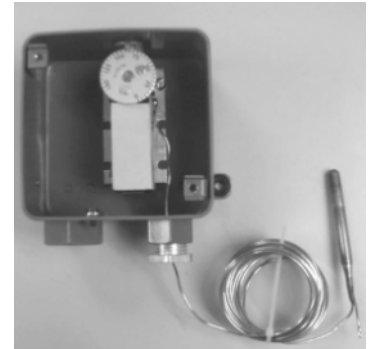

Fig. 1 -- Interior of an A19ANC thermostat.

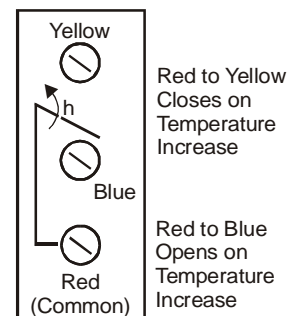

Fig. 2 – Designations and Switch Action

### Specifications

Type Number	A19ANC	SPDT Switch Action, Standard Differential (Fixed)
	A19ANF	SPDT Switch Action, Close Differential (Fixed)
	A19APC	SPDT Switch Action, Standard Differential (Adjustable)
Range, Maximum Temperature and Differential*	See Selection Chart	
Capillary	.062" (1.6 mm) O.D. Standard Length is 10' (3 m)	
Enclosure	Rainproof with Gasketed Cover (NEMA 3R)	
Finish	U.L. Listed Outdoor Gray Enamel	
Material	.062" (1.6 mm) Cold Drawn Steel	
Switch	Snap-Acting Contacts in Dust Protected Enclosure	
Conduit Opening	Welded 3/4" Female Connector	
Wiring Connections	Screw Type Terminals	
Mounting	Three Rubber Cushioned Mounting Feet	
Shipping Weight	2.3 Lb (1.0 kg)	

\*Differential is based on direct bulb immersion in liquid at 1F° (0.6C°) per minute rate of change.

The red to blue terminals open on a temperature increase (See Fig. 2).

Simultaneously, the circuit between red and yellow closes.

The thermostats have an adjustable high temperature stop. A special wrench (Part 836-61) required to adjust the keyed stop is provided with each thermostat.

The A19ANC and A19ANF thermostats have a fixed differential.

The A19APC thermostat has a lever for adjustment of the differential between minimum and maximum values (See Product Selection Chart).

## Optional Constructions

### Sensing Elements

See Product Selection Chart for standard capillary lengths. Other lengths are available. Contact a Johnson Controls representative.

### Bulb Well

Copper bulb wells with 1/2 in. NPT brass connectors are sold separately. See Product Selection Chart for ordering information. For special applications requiring a connector made with a different metal, contact a Johnson Controls representative for availability.

### Installation

**WARNING: Risk of electrical shock.** Disconnect power supply before wiring connections are made to avoid possible electrical shock.

**CAUTION: Risk of equipment damage.** Disconnect power supply before wiring connections are made to avoid damage to the equipment.

**Note:** Use terminal screws furnished (8-32 x 1/4 in. binder head). Do not substitute screws of a different size. Make all wiring connections using copper conductors only, and in accordance with the local, national, and regional regulations.

Indoors, mount the thermostat in any position by means of three mounting feet. When the thermostat will be exposed directly to the outdoor weather, mount the thermostat with the electrical conduit, capillary fittings, and drain hole facing downward as illustrated in Fig. 1.

Ambient rating (not bulb maximums) 140°F (60°C).

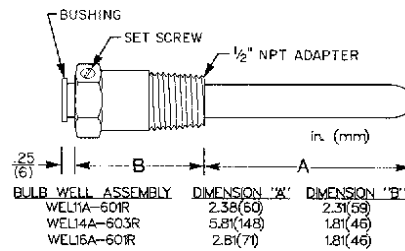

Fig. 3 – Bulb well dimensions

**IMPORTANT:** Do not dent or deform the sensing bulb of this control. A dent or deformation will change the calibration and cause the control to cycle at a temperature lower than the dial setting.

Where the capillary is exposed and subject to possible mechanical damage some means of protection should be provided. The capillary outlet is designed to permit the capillary to be run through 1/2 in. thin wall or flexible conduit. Remove the capillary outlet seal nut. (See Fig. 4.) Push the bulb and capillary through a conduit coupling or suitable hose fitting and on through the conduit or hose. By tightening the coupling to the 1/2 in. female capillary outlet fitting, the seal around the capillary will be maintained and the conduit or hose will be rigidly attached to the enclosure.

### Adjustments

**WARNING: Risk of electrical shock.** To avoid the risk of electrical shock, disconnect the power supply before making any adjustments to avoid possible electrical shock.

## Product Selection Chart

Product Number	Range °F (°C)	Differential F° (C°)	Maximum Allowable Temp °F (°C)	Capillary Length Ft. (m)	Bulb Size	Bulb Well (if required)
A19ANC-1	0 to 150 (-18 to 66)	5 (2.8)	190 (88)	10 (3)	0.290 x 2 1/2"	WEL11A-601R
A19ANC-2	100 to 250 (38 to 121)	6 (3.3)	290 (143)	10 (3)	0.290 x 2 1/2"	WEL11A-601R
A19ANC-3	200 to 350 (93 to 177)	5 (2.8)	390 (199)	10 (3)	0.366 x 2 1/4"	WEL16A-601R
A19ANF-3	20 to 90 (-6.7 to 32)	2 (1.1)	130 (54)	10 (3)	0.366 x 2 5/8"	WEL16A-601R
A19APC-1	20 to 90 (-6.7 to 32)	3.5 to 14 (1.9 to 7.8)	140 (60)	6 (1.8)	0.375 x 5"	WEL14A-603R

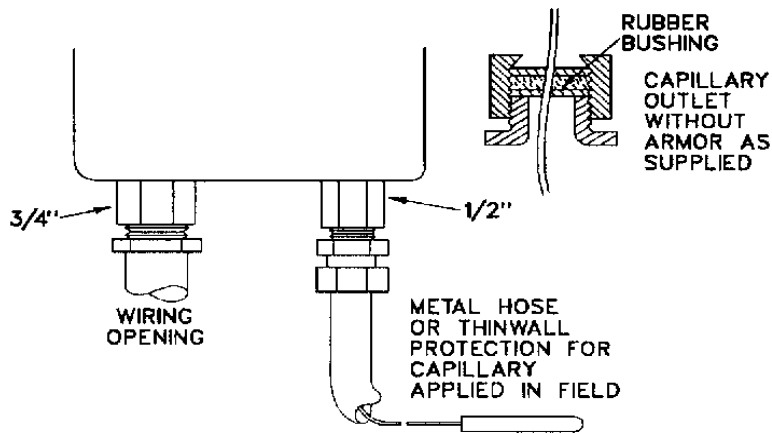

Fig. 4 – Typical installation where capillary protection is required

To change the temperature setpoint, remove the cover, and rotate the dial to the desired setpoint with a screwdriver. Replace cover, and verify that gasket is sealed.

**Adjustable Differential (A19APC only)**

Models with adjustable differential are factory set at minimum differential. To adjust, move the lever between maximum and minimum.

**Adjustable Maximum Setpoint Stop**

To change the stop setting, loosen the two screws in the dial plate with the wrench included with the control. Turn the dial so the pointer indicates the stop setting.

Move the stop (located behind the dial plate) against the stop bracket. Tighten screws to lock the stop in position.

High cutout stop can be set between 55F° (31C°) above the bottom of the range and the top of the range. Example: The high temperature stop can be set between 255 to 350°F (124 to 277°C) on a control with a range of 200 to 350°F (93 to 177°C).

**Checkout Procedure**

Before leaving the installation, observe at least three complete operating cycles to be sure that all components are functioning correctly.

**Repairs and Replacement**

Field repairs must not be made except for replacement of the bulb well and cover. For a replacement thermostat, bulb well, or cover, contact the nearest Johnson Controls distributor.

**Electrical Ratings**

**A19ANC, A19APC**

Voltage, AC Only		120	208	240	277
Full Load Amps		16.0	9.2	8.0	—
Locked Rotor Amps.		96.0	55.2	48.0	—
Non-Ind. Amps.	When connected — SPST	22.0	22.0	22.0	22.0
	When connected — SPDT	16.0	9.2	8.0	6.9
Pilot Duty — 125 VA, 24/600 VAC					

**A19ANF**

Voltage, AC Only		120	208	240	277
Full Load Amps.		6.0	3.4	3.0	—
Locked Rotor Amps.		36.0	20.4	18.0	—
Non-Inductive Amps.		10.0	10.0	10.0	10.0
Pilot Duty — 125 VA, 24/277 VAC					

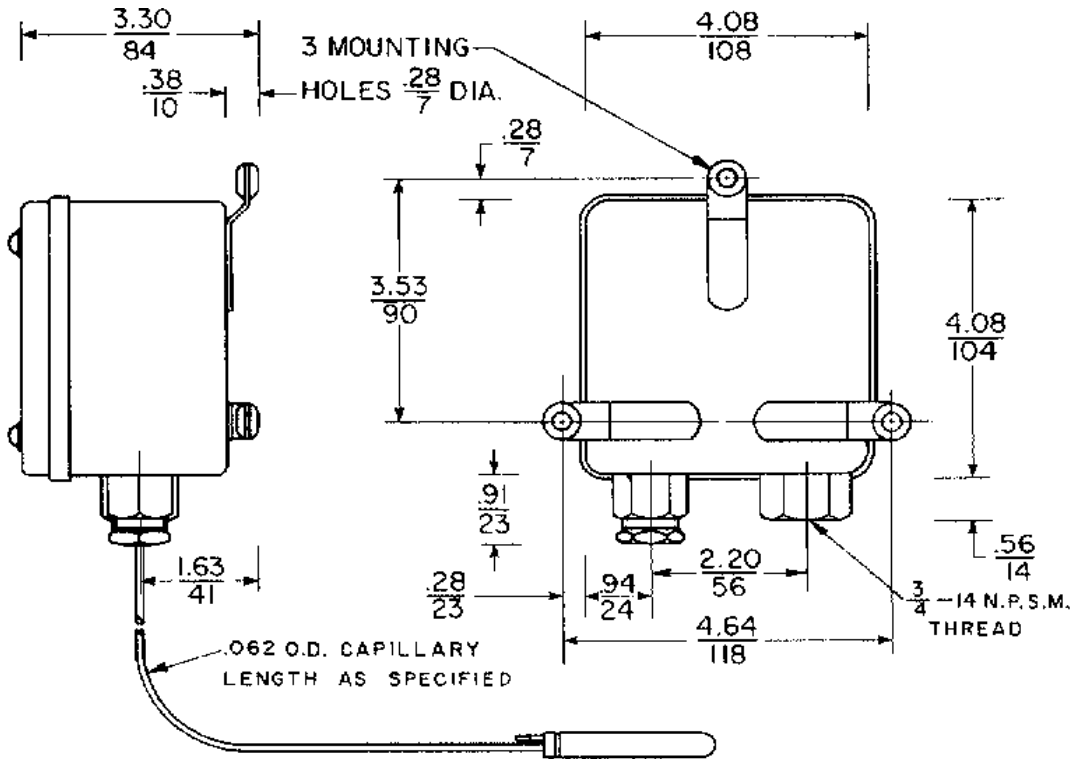

**A19 Dimensions  $\frac{\text{In.}}{\text{mm}}$**

*Performance specifications appearing herein are nominal and are subject to accepted manufacturing tolerances and application variables.*

UL Guide No. XAPX  
File E6688

**JOHNSON  
CONTROLS**

**Controls Group**  
507 E. Michigan Street  
P.O. Box 423  
Milwaukee, WI 53201

Published in U.S.A.  
[www.johnsoncontrols.com](http://www.johnsoncontrols.com)