

Dayton Sewage Pumps



PUMPS technical data sheet

Submersible Sewage pumps are designed to remove sewage wastewater from a residential home or commercial office. These pumps are designed to pass the typical suspended solids associated with sewage wastewater. Sewage pumps typically operate intermittently and automatically with a float switch and can accommodate solids up to 2" in diameter.



4HU86
1½ HP, Cast Iron
Submersible Sewage Pump

HP	1-1/2
Voltage	240V
Phase	Single
Frequency	60 Hz
Run Amps	13.5A
Start Amps	31.5A
RPM	3450
Motor Type	PSC Hermetically Sealed/Oil Filled

Overload Protection	Internal Thermal Overload
Motor Shaft Material	Stainless Steel
Motor Housing Material	Cast Iron
Motor Duty	Continuous
Motor End Bearing	Single Row Ball
Pump End Bearing	Single Row Ball
Lubrication	Oil Lubricated
Discharge	2 Inch Flanged, Vertical
Volute Material	Cast Iron
Base Material	Cast Iron
Impeller Type	Open Vortex
Impeller Material	Cast Iron
Hardware Material	Stainless Steel
O-rings	Buna-N
Seal Type	Single Mechanical
Seal Materials	Silicon Carbide/Silicon Carbide/Buna N
Operation	Automatic / Tethered Switch
Power Cord	14/3 SOW, 20' (6.1m), NEMA 6-15P 240V Plug
Max. Solids Handling	2" (51mm) spherical
Max. Water Temperature	104°F (40°C)
Designed Fluid Environment	Water / Sewage Wastewater
Switch Type	Tethered
Switch Cord	20' (6.1m) SJOW Power Cord
Switch Plug	NEMA 6-15P Piggyback Plug
Switch Max. Run Amps	15A
Switch Max. Start Amps	60A
Switch Pumping Range	Variable – Discharge Pipe Mounted

Outline Dimensions

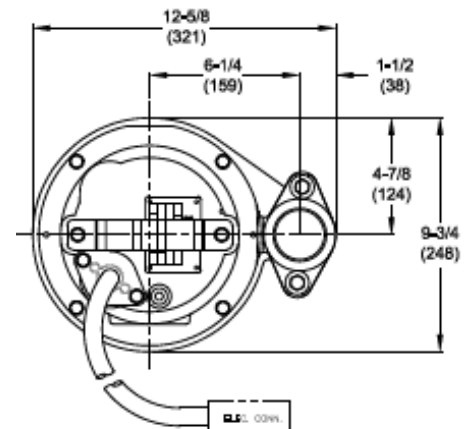
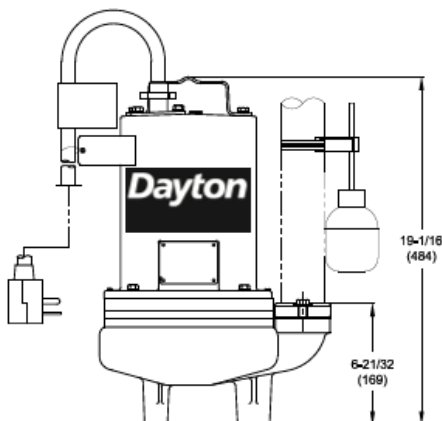

Performance Data

Head	Feet	20	25	30	35	40	45	50	55	60	65	66
	Meters	6.1	7.6	9.1	10.7	12.2	13.7	15.2	16.7	18.3	19.8	20.1
Flow Rate	GPM	145	135	125	112	100	85	70	55	35	7	0
	LPM	549	511	473	424	379	322	265	208	132	26	0

Performance Chart

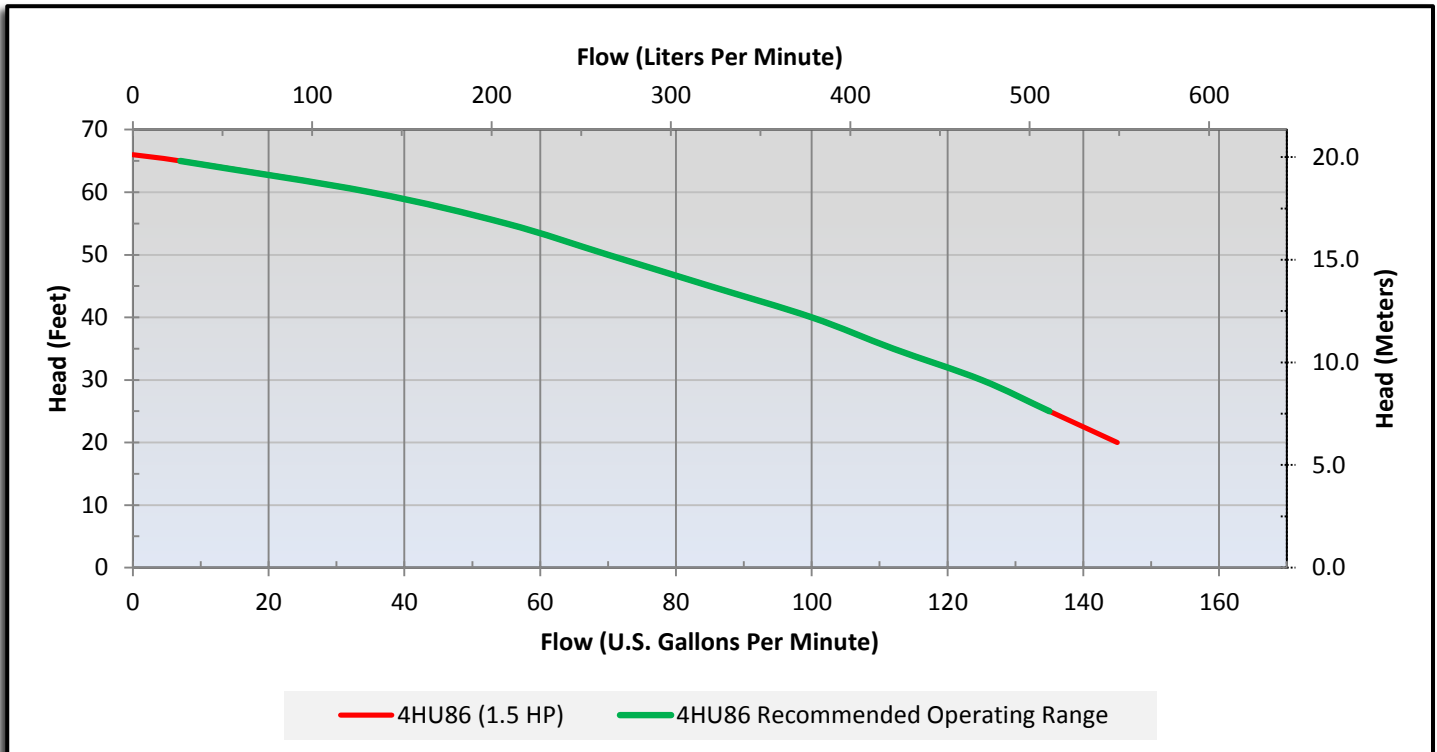

WARNING: Use only with nonflammable liquids compatible with pump component materials and in nonflammable/nonexplosive atmospheres.

Call or visit your local branch or go to grainger.com/dayton for complete product line information

Find it at Grainger.

© 2013 W.W. Grainger, Inc.

