

## DAYTON AIR-OPERATED DOUBLE DIAPHRAGM PUMP DATA SHEET 22A595, 22A596



22A595



22A596

### Technical Specs

SHIPPING WEIGHT	165.0 LBS	165.0 LBS
MAXIMUM LIQUID TEMPERATURE	180°F (82°C)	212°F (100°C)
INTAKE & DISCHARGE PORTS	3" PORT, FLANGED	3" PORT, FLANGED
FLOW	0 - 215 GPM MAX	0 - 215 GPM MAX
MAX AIR SUPPLY PRESSURE	100 PSI (1.4 - 7 KGF/CM <sup>2</sup> )	100 PSI (1.4 - 7 KGF/CM <sup>2</sup> )
BODY MATERIAL	ALUMINUM	ALUMINUM
LIFT-DRY, WET	19 FT, 28 FT	19FT, 28 FT
<b>AIR VALVE</b>		
LUBRICATION	NO LUBRICATION REQUIRED	NO LUBRICATION REQUIRED
MANUAL OVERRIDE	YES	YES
<b>LIQUID SIDE</b>		
EASY REPAIR	YES	YES
BALL CHECK VALVE	BUNA N	SANTOPRENE®
O-RINGS	BUNA N	EPDM
DIAPHRAGMS	BUNA N	SANTOPRENE®

# DAYTON AIR-OPERATED DOUBLE DIAPHRAGM PUMP

22A595, 22A596

## Dimensional Drawing

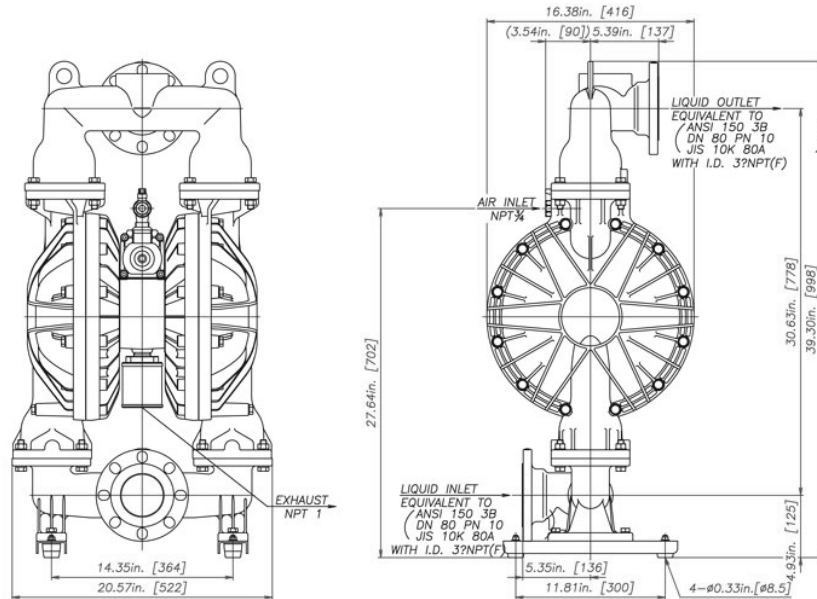

## Performance Curve

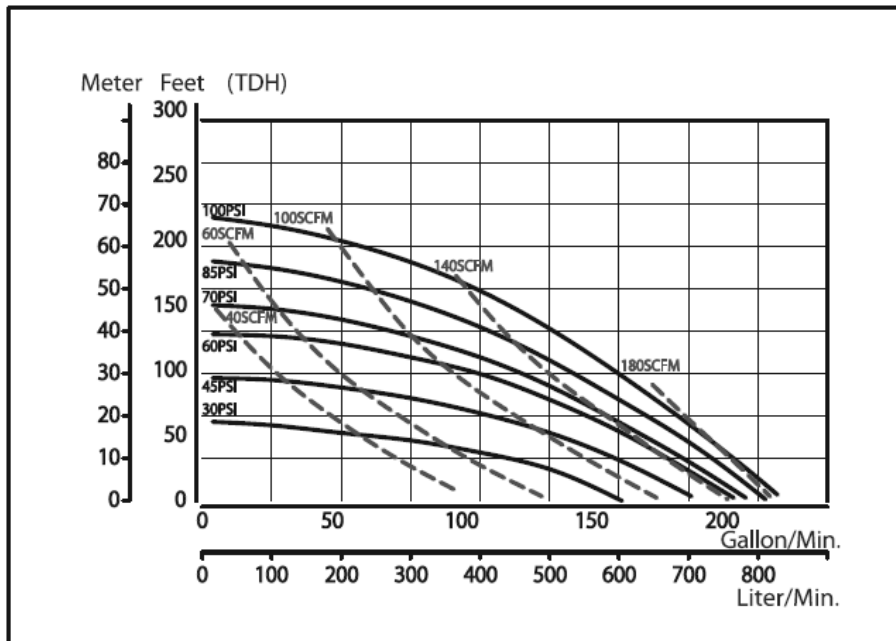

Find it at Grainger.

Call or visit your local branch or go to [grainger.com/dayton](http://grainger.com/dayton) for complete product line information.

**Dayton**®