

No. 100A Leg and Tray Stand

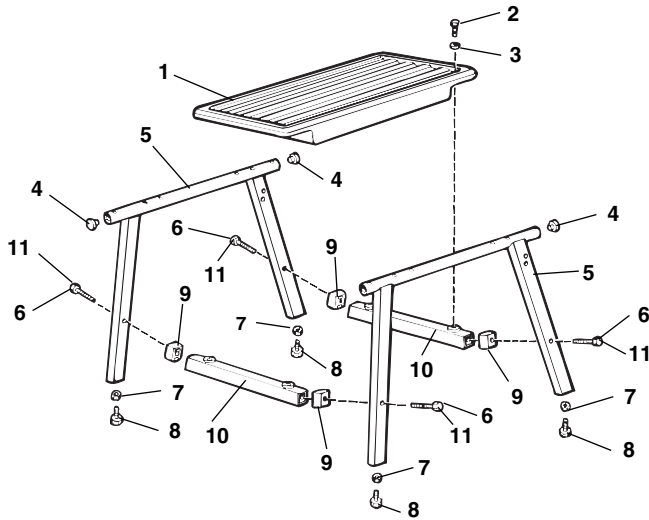

**NOTE: Order parts by Catalog Number only.
DO NOT order by Reference Number.**

Ref. No.	Catalog No.	Description
—	92457	Leg Stand Assembly
1	56872	Tray
2	80030	Hex Bolt $\frac{3}{8}$ " - 16 x 1" (4)
3	44230	Flat Washer $\frac{3}{8}$ " (4)
4	58037	End Cap (4)
5	58022	Leg (2)
6	58052	Hex Bolt $\frac{3}{8}$ " - 16 x 2 $\frac{1}{2}$ " (4)
7	44225	Hex Nut $\frac{3}{8}$ " - 16 (4)
8	58027	Leveling Pad (4)
9	58042	Spacer (4) - (1224 Machine Only)
10	58032	Cross Member (2)
11	58047	Hex Bolt $\frac{3}{8}$ " - 16 x 4" (4) (1224 & 535 Auto Machine Only)

NOTE: $\frac{3}{8}$ " - 16 x 4" Bolts and spacers used when mounting 1224 & 535 Auto machines.

No. 150A/200A Wheel and Tray Stands

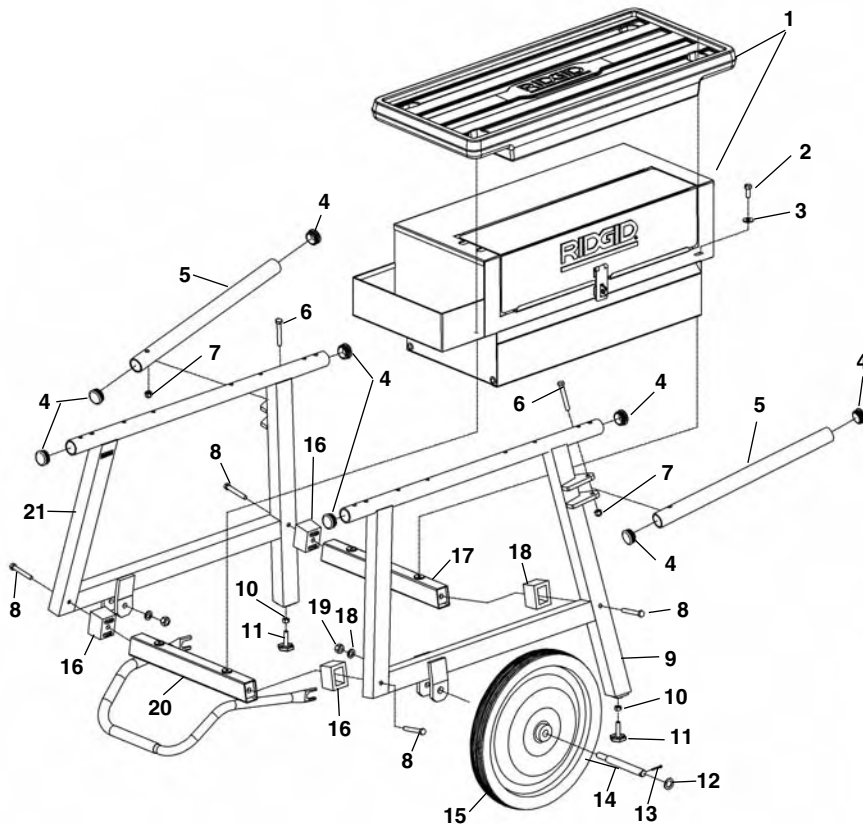

Ref. No.	Catalog No.	Description
—	92462	150A Wheel and Tray Assembly
—	92467	200A Wheel and Cabinet Assembly
1	56872	Tray
	22563	Cabinet
2	80030	Hex Bolt $\frac{3}{8}$ " - 16 x 1" (4)
3	44230	Flat Washer (4)
4	58037	End Cap (6)
5	58067	Handle (2) includes Ref. No. 6
	34843	Handle - Type 2 (2)
6	46675	Hex Bolt $\frac{3}{8}$ " - 16 x 2 $\frac{3}{4}$ " (2)
7	79985	Locknut $\frac{3}{8}$ " - 16 (2)
8	58052	Hex Bolt $\frac{3}{8}$ " - 16 x 2 $\frac{1}{2}$ " (4)
	58047	Hex Bolt $\frac{3}{8}$ " - 16 x 4" (4) (1224 & 535 Automatic Machine Only)
9	26788	Front Leg
10	44225	Hex Nut $\frac{3}{8}$ " - 16 (4)
11	58027	Leveling Pad
12	47180	Washer (2)
13	47030	Cotter Pin (2)
14	58072	Axle (2)
15	27442	Wheel (2)
16	58042	Spacer (4) (1224 & 535 Automatic Machines Only)
17	58032	Front Cross Member
18	84150	Lock Washer $\frac{1}{2}$ " (2)
19	44745	Locknut $\frac{1}{2}$ " (2)
20	26798	Rear Cross Member w/Stand Stop Assembly
21	26793	Rear Leg

NOTE: $\frac{3}{8}$ " - 16 x 4" bolts and spacers used when mounting 1224 & 535 Auto machines.