

M-6327 2

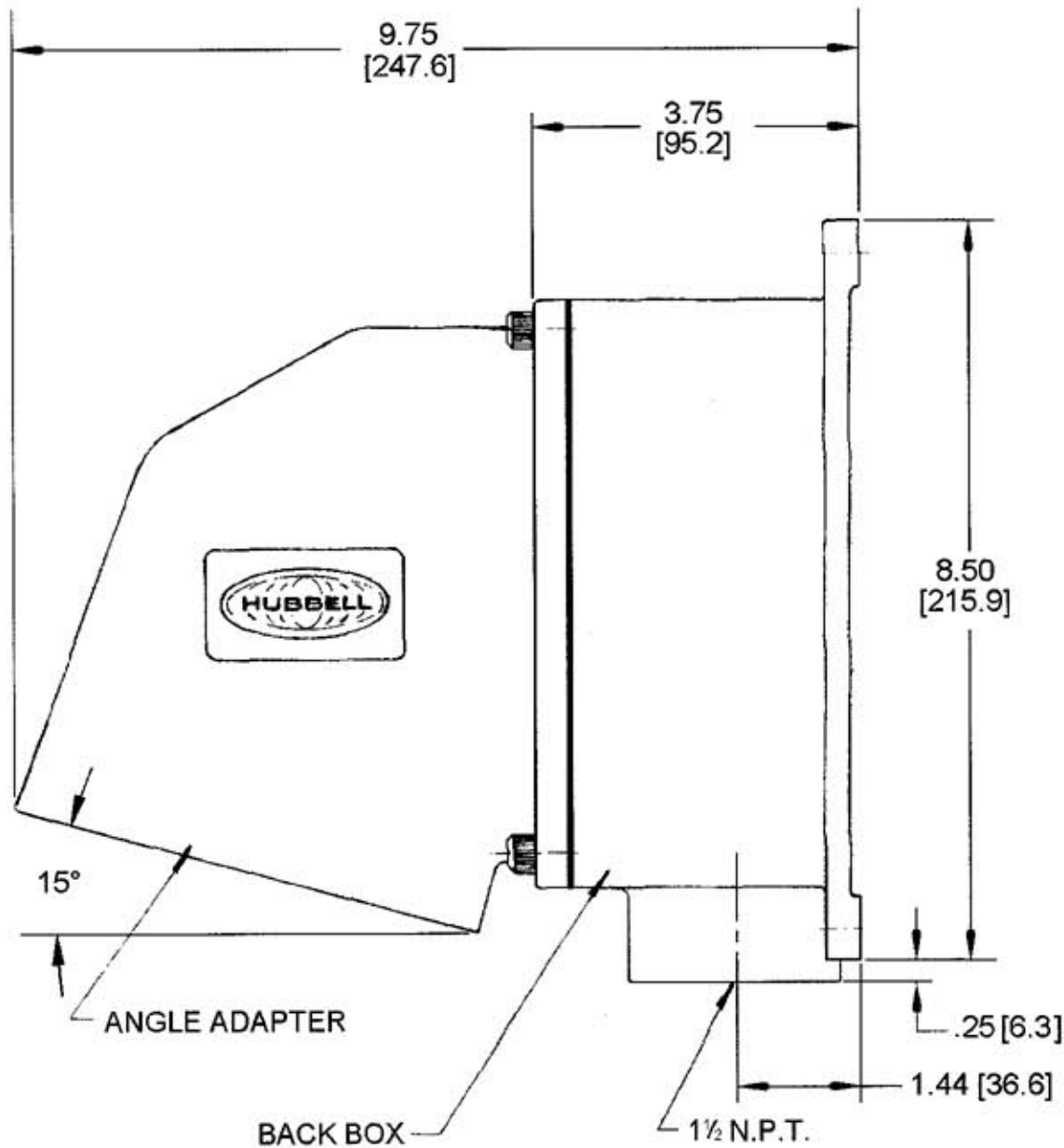
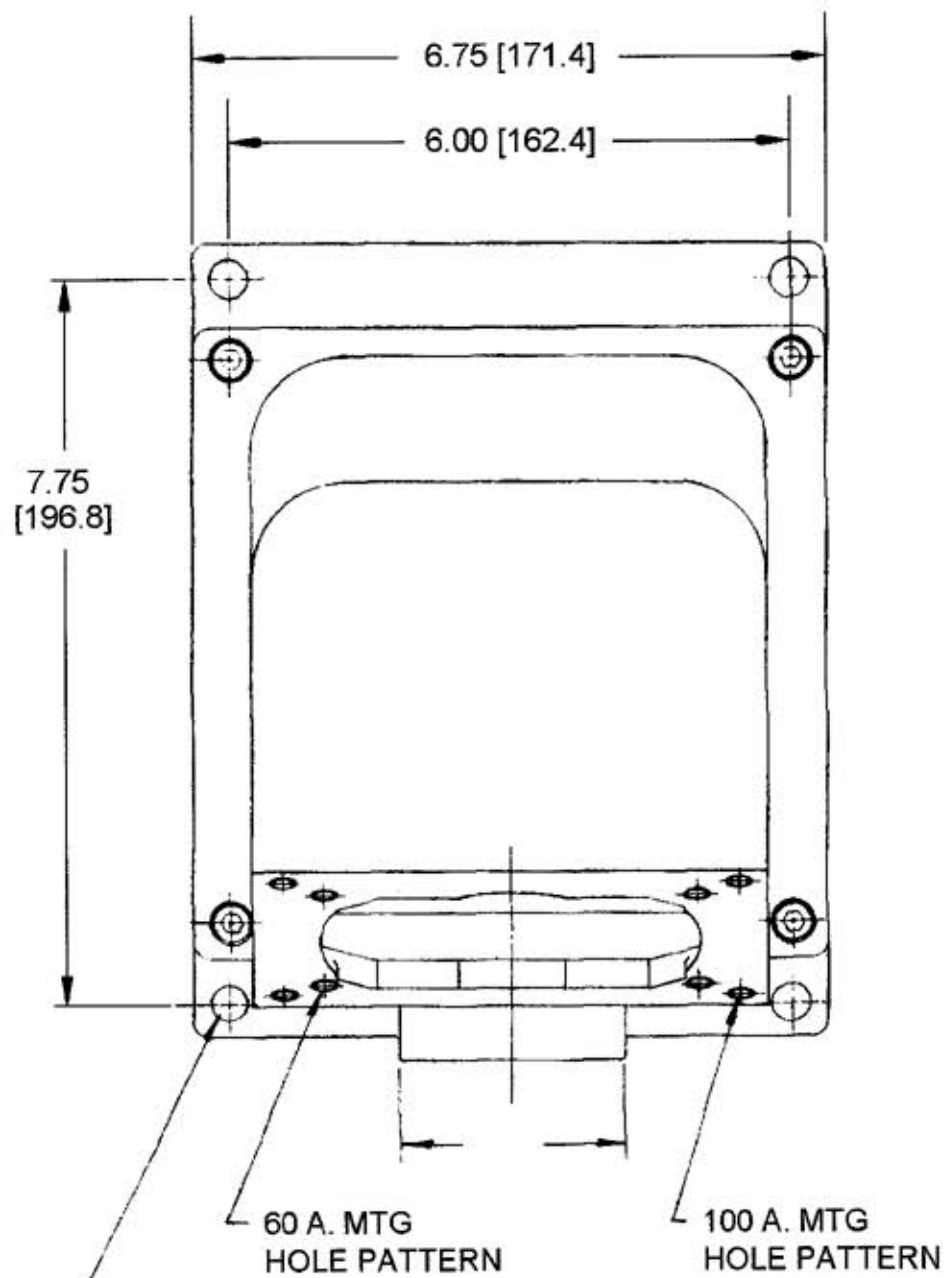

NOTES (UNLESS OTHERWISE SPECIFIED)

- 1) ANGLE ADAPTER CAN BE MOUNTED TO BOX SO THAT THREADED HUB CAN POINT IN ANY ONE (1) OF FOUR (4) DIRECTIONS.
- 2) TOLERANCES ARE:  
DECIMALS ± .03  
ANGLES ± 2°
- 3) DIMENSIONS ARE: INCHES [MILLIMETERS]

CAT. NO. FW60100

TITLE FW 60/100 PIN & SLEEVE FOUR WAY ANGLE ADAPTER & BACK BOX

LIST OF PARTS

DESCRIPTION	MATERIAL	FINISH
BACK BOX	ALUMINUM	GRAY PAINT
ANGLE ADAPTER	ALUMINUM	GRAY PAINT
HEX SOCKET HD. CAP SCRS.	STEEL	ZINC PLATE
GASKET	NEOPRENE	
WASHER	ALUMINUM	
SCREW	STEEL	

SYM	REVISIONS	APP	DATE
2	REMOVED ±.015 FROM DIM.'S AND "11 ½" AND "TAP" FROM THREAD CALL-OUT. ADDED METRIC EQUIVALENTS TO DIM.'S, 15° & 1.44 DIM.'S, AND NOTES 2 & 3. IN LIST OF PARTS, ADDED WASHER AND SCREW; "ZINC PLATE" WAS "CAD PLATE". 2 PLACE DECIMAL INCH DIMENSIONS WERE 3 PLACE PER DCN # 12944. JMN	DJP	7/10/06
1	CONVERTED ALL DIMS TO 3 PL DECIMAL, ADDED TOL., CAT NO WAS FW 60/100, PER DCN #7793 AMZ DB		7-18-00

TOLERANCES UNLESS OTHERWISE SPECIFIED		HARVEY HUBBELL, INC.	
FRACTIONS ± 1/64		BRIDGEPORT, CONN.	
DECIMALS ± .005		DR. BY ASM	APP. BY DJC
ANGLES ± 2°		TR. BY	SCALE ½ SIZE
		CHK'D. BY	DATE 11-17-82

DIMENSION SHEET FOR CAT. NO. FW 60100

REPAIRABLE  NON-REPAIRABLE

B M-6327

2