



MADE IN THE USA

Companion Products (each sold separately):

- ED-097
- FD-062
- FD-068
- FD-111
- FD-112
- PS014-0212
- RS001-0212
- RS001-0512
- RS002-0212
- RS002-0512
- RS004-0512
- RS005-0212
- RS005-0512



RS001-0512 and MP-075
on KS010-0412



RS001-0212 and MP-070
on KS010-0412



RS005-0512 and MP-075
on KS010-0412

Product Description:

- Floor Stand - Accommodates a variety of BOWMAN® Respiratory Hygiene Stations
- Column with square base and mounting top plate for companion product
- Hardware is included
- Made of Quartz Beige Powder-Coated Steel

Primary Area for Product Usage:

- Ports of entry: waiting rooms, lobbies, elevators
- Medical offices or clinics

Dispenses:

Most major manufacturers' standard glove boxes:

- Boxes no larger than 5.50"W x 10.00"H x 3.75"D (14.0 cm x 25.4 cm x 9.5 cm)

Package Specifications:

- Package Quantity: 1 per case
- 36"L x 20"W x 6"H (91.4 cm x 50.8 cm x 15.2 cm)
- 20.0 lbs (9.1 kg) - approximated

Product Specifications (overall external dimensions):

- 18.00"W x 36.06"H x 18.00"D (45.7 cm x 91.6 cm x 45.7 cm)
- 16.0 lbs (7.3 kg) - approximated

Mounting Specifications:

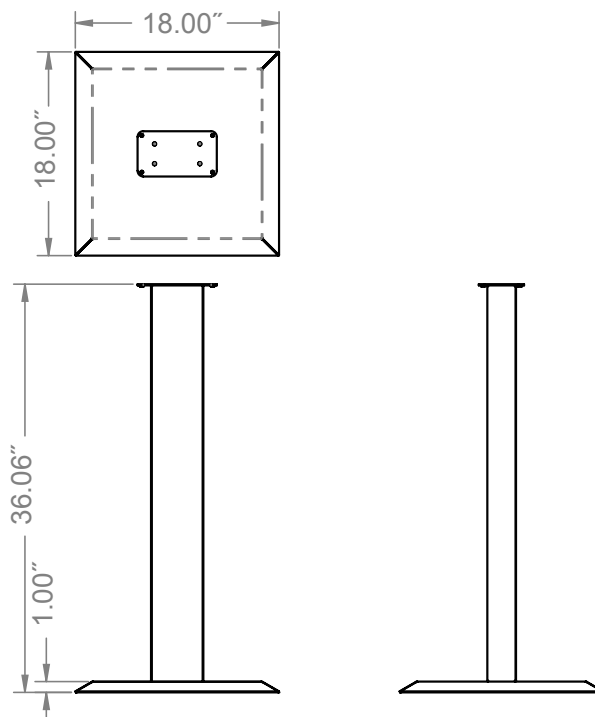



Installation

Always mount dispensers securely *prior* to loading with product.

- To secure base to column, turn column upside down (with top plate down).
- Place base inverted, as shown, on column.

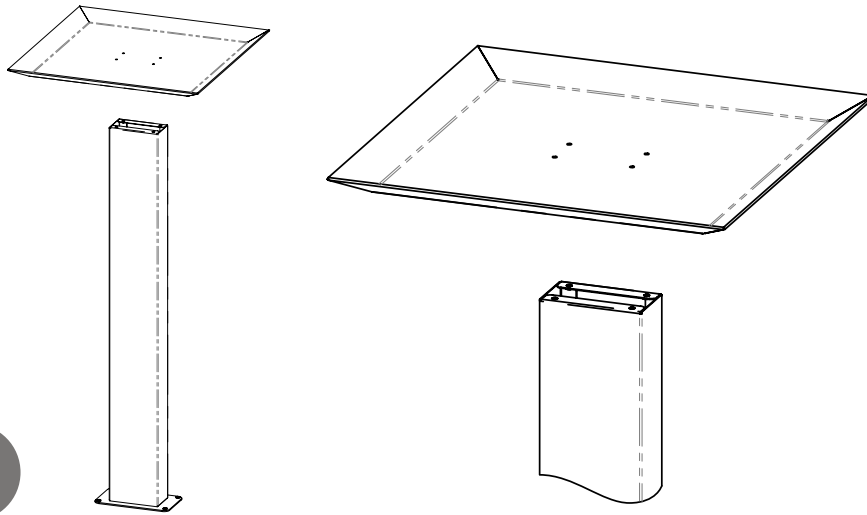

1

- Use Phillips screwdriver to secure base to column with (4x) screws (10-32 x 5/16").
- Turn stand right side up, so the base is on the floor.

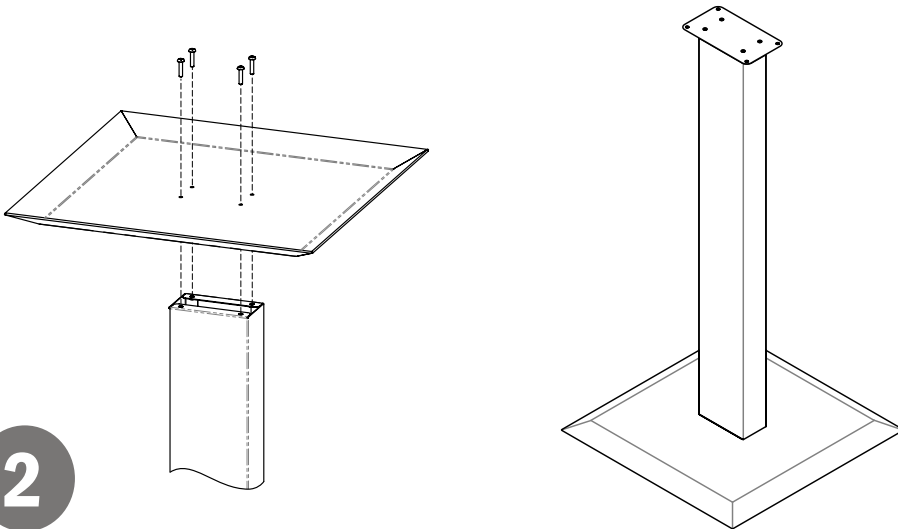

2

Parts included:

- Column
- Base
- Hardware
- (8x) Screws: (4x) for stand, (4x) included to attach companion product (Phillips type 10-32 x 5/16")

Tools Required:

- Phillips screwdriver

Care and Construction Powder-Coated Steel

Material Characteristics

Designed for Long-Term Use

Our steel dispensers and stands are coated with polyester powders which makes them highly resistant to corrosion.

Powder-coated steel is ideal for dispensers used in a healthcare or an industrial setting because it is impact resistant and is not effected by extremes in temperature.

Dispensers and stands made of powder-coated steel are both attractive and functional, providing years of service.

Care and Cleaning

For best results, clean by washing the surface with a diluted solution of a mild, non-abrasive detergent in cold or warm water and a non-abrasive cloth. Standard hospital cleaning supplies can be used. Dry with a soft cloth. Do not use any solvent-based materials, abrasives (e.g. Scotch-brite, steel wool), or apply excessive force during cleaning.