

Please read and save these instructions, read carefully before attempting to assemble, install, operate or maintain the product described. Protect yourself and others by observing all safety information. Failure to comply with instructions could result in personal injury and/or property damage! Retain instructions for future reference.

Description

This **Drum Lifter** is a professional tool used for lifting, transporting and stowing 55 gallon closed-head steel drums. It is designed with a safety lock pin that prevents drums from opening when being transported and a lifting eye that is mounted on top of four 1/4 x 1" hot-rolled steel brackets.

Model	12R542
Max. Weight Capacity	700 Lbs
Drum Type Lifted	55 gallon closed-head steel drums
Net Weight	20 Lbs
Overall Dimension	H =13-1/2", W= 23", D =28-1/4", Dia.=1-1/2"



Unpacking

When unpacking your unit , check carefully for shipping damage. If damage has occurred, immediately file a claim with the carrier.

General Safety Information

Warning: The Economy Drum Lifter is intended for specific functions. Please adhere to the following instructions to ensure safe and proper use.

- This drum lifter is designed for lifting drums in vertical position only.
- SAFETY PIN MUST BE INSTALLED BEFORE LIFTING DRUM.
- The drum must have a top lip.
- Maximum capacity - 700 Lbs. Do not load the drum lifter beyond its rated capacity. Injury to person or property may result from overloading, misuse, or carelessness.
- Inspect the drum lifter before each use. If there is damage or distortion to any part, the drum lifter must be removed from service until it is repaired or replaced.
- Make sure the drum is secured by the lifting arms before lifting.
- Do not allow anyone to stand beneath a raised drum.
- Never leave a drum unattended in the raised position.
- Do not use this drum lifter for other than its intended use. **NOT FOR USE WITH FIBER OR PLASTIC DRUMS!**
- Failure to comply with these warnings may result in personal injury and/or property damage.

Operation

1. Attach the drum lifter vertically to the hook of your hoist, chain block, etc.
2. Lower the drum lifter over the drum, Open the handle and then put the drum holder to lock the drum.
3. Operate the handle to lock the drum firmly, and then install the safety pin to prevent the drum from tilting.
4. Carefully move the drum to desired location. When the drum has been lowered completely to the floor or pallet, allow the drum lifter to slacken and move it away from the drum.

Maintenance

- (1) Lubricate moving parts periodically.
- (2) Check bolts and nuts frequently for tightness.

Exploded view and Parts list

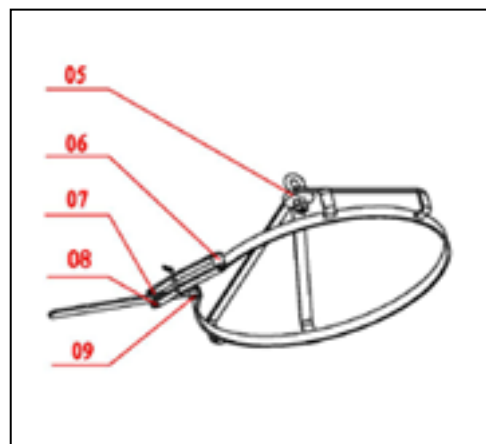
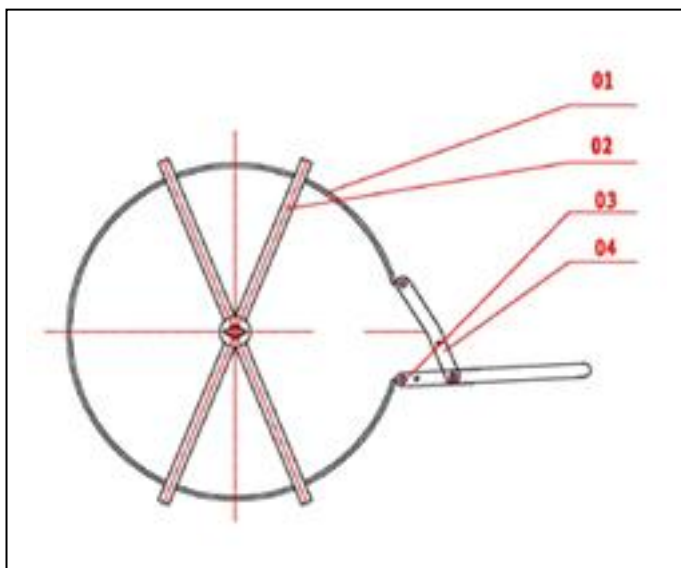

Item	Part No	Qty	Description
1	DLG350-01	1	Loop Ring
2	DLG350-02	4	Beam Plate
3	DLG350-03	1	Handle
4	DLG350-04	1	Connection Bar
5	DLG350-05	1	Hook Plate
6	DLG350-06	1	Hinge Busher
7	DLG350-07	4	Washer
8	DLG350-08	2	Shaft
9	DLG350-09	1	Shaft-S